

High-Speed Fiber Placement on Large Complex Structures

Russell DeVlieg, Kyle Jeffries, Peter Vogeli
Electroimpact, Inc.

Copyright © 2007 SAE International

ABSTRACT

Automated Fiber Placement (AFP) equipment has been developed capable of laying fiber in excess of 2000 inches per minute on full-size, complex parts. Two such high-speed machines will be installed for production of a nose section for a large twin-aisle commercial aircraft fuselage at Spirit AeroSystems in Wichita, Kansas along with a rotator for the fuselage mandrel. The problem of cutting and adding on the fly at these speeds requires thorough re-evaluation of all aspects of the technology, including the mechanical, controls, servos systems, and programming systems. Factors to be considered for high speed cut and add on the fly are discussed.

INTRODUCTION

Recent demand for large complex structures made up of CFRP (carbon fiber reinforced plastic) has driven the laydown rate requirements for automated fiber placement machinery to much higher levels. Generally, more complex curvature necessitates narrower tow. As tow width decreases, the resulting course width (tow width multiplied by the number of tows being placed in a single pass by the machine) decreases. This yields a lower laydown rate. Consequently, to manufacture massive complex structures, such as aircraft fuselage sections, using conventional equipment would necessitate a multitude of multi-axis machines spread across multiple cells in order to meet demand.

The economics of building large aircraft components, however, argues strongly against multiple machines - each operating at low rates - regardless of the cost of the machines. The cost of the tooling and the cost of the clean room factory space required per machine may each exceed the cost of the AFP equipment by several times, and many of the costs of operation of the AFP equipment are independent of the laydown rate.

To minimize tooling, clean room and operating costs, increasing the laydown rate was the obvious next step. High laydown rates require cutting and adding at high speed and within the customer's accuracy requirements. Maintaining accuracy on simple "flat" parts, or during a well-defined test or demonstration is relatively easy. Due to the well-defined geometry and operating conditions, most errors can be compensated for. Maintaining

accuracy on realistic lay-downs under realistic factory conditions is more difficult.

A realistic laydown includes many short courses, ramps or other contoured features, and bi-directional laydown for speed. The machine will be required to continuously accelerate in multiple axes during the laydown to maintain the surface normals required for compaction on these complex parts. The speed of the laydown will be adjusted on-the-fly by the operators for many reasons, and part programs should not have to be "re-posted" for feed rate changes.

Four primary areas of the technology need to be addressed for accurate end placement under realistic conditions. They are:

- 1) Mechanics and actuation of the cutting and adding, including roller conformance and part issues
- 2) Control and timing of the cutting and adding
- 3) Servo controls, including accuracy, servo lag and following error
- 4) Programming system

Electroimpact has developed AFP technology that allows cutting and adding within customer end placement tolerances at rates up to 2000 IPM over ramped, complex surfaces. All layups can be performed fully bi-directionally and with operator control over the feed rate with no effect on end cut accuracy.

MAIN SECTION

CUTTING SYSTEM MECHANICS

A series of issues arise from high speed cutting on the fly. Retaining cut quality requires a re-evaluation of the mechanical workings of the cutter module and internal tow guidance system. To maintain cut placement, timing becomes critical necessitating high speed computing for precision in positioning.

There are many ways to cut carbon tow, all with virtues and trade-offs. For example, the rotary cutting system, developed by MTorres, relies on individual servo motors

for every tow to perform cuts on-the-fly (see “references”). The most commonly found and proven design for cutting carbon fiber tow is the guillotine-style cutting system, consisting of an actuated blade and shear edge. It’s simplicity enables optimal packaging, high-reliability, and minimal control systems. It also is inherently expandable. The cutting module and shear edge(s) are integrally incorporated into the tow guiding system (guide chutes) whereby the tow is fed between the shear edge and the blade.

Cutting Technology

Conventional blade arrangement is as shown in figure 1. In the direction of tow extraction, the shear edge is first, followed by the blade. When cutting on the fly, the material is continuously being pulled through the head, so during a cut as the blade enters the moving material, the yet to be cut fibers continue to be extracted. This results in the blade being pulled away from the shear edge. As there must be some clearance in the blade guide, a gap is introduced yielding reduced cut quality, rapid resin build-up, and at high speeds, eventual cut failure (tow not completely separated).

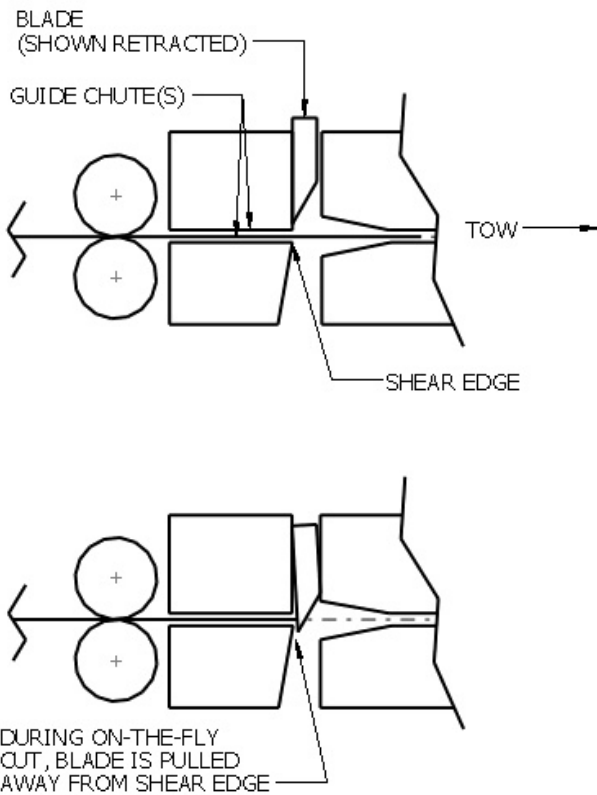

Figure 1 – Traditional cutting technology

A novel way of combating the blade being pulled away from the shear edge is to essentially flip the system around to present the blade first (Figure 2). As the tow is cut, the blade is now pulled into the shear edge. This guarantees that at the point of cut, the blade edge and the shear edge are in contact, similar to how a good pair of scissors function. As a result, the quality of the cut

can actually improve as the laydown rate is increased. Successful cutting has been repeatedly demonstrated at speeds exceeding 2500 IPM while still remaining within customer-defined placement tolerances.

With the blades in this configuration, tow guidance and chute design must change. After the tow is cut, it must then be fed back down to the part to begin a new course. Since the tow is not necessarily straight, it can easily snag on the shear edge without proper guidance. Consequently, this would result in a feed jam at the beginning of the next course.

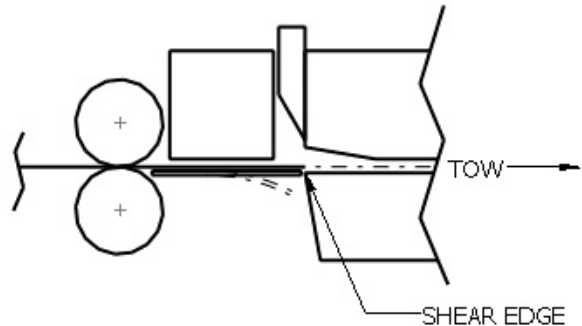

Figure 2 – Optimized for cutting on-the-fly

As the guide chute must be present in one case (to direct the tow past the shear edge), yet not present in another (when the blade is fully actuated), a new guide chute system was engineered by Electroimpact. This patent pending design has enabled high-speed operation with high reliability.

Actuation

At rest, the velocity of the blade is somewhat irrelevant with respect to cutting other than some inertial help gained from the mass of the blade and it’s actuating components. With the tow in motion, however, it is desirable to pass thru the material at high speed to limit the amount of time the blade is in the material. Typically for reasons of packaging, blade actuation is accomplished via pneumatic cylinder in conjunction with a lever or linkage system. The lever or linkage can aid by providing mechanical advantage to the blade, decreasing the required force output from the pneumatic cylinder. Low cylinder force keeps the size to a minimum and/or allows for low pressure actuation. The drawback, however, is the blade velocity is decreased and the cylinder stroke is increased. At high laydown rates this becomes problematic.

The time it takes for the blade to pass thru the material (cut time) is critical. More specifically, this is the amount of time elapsed from the moment the edge of the blade enters the first fiber in a single tow until the last fiber in the tow is cut. For high-speed on-the-fly applications, it is crucial to minimize this. As an example, assume the laydown rate is 2000 IPM (R) and the end of cut

placement tolerance is +/-0.050" (or 0.10" total [k]). The window of opportunity in time is as follows:

$$T = (60 * k) / R \text{ (seconds) or,}$$

$$T = (60 * 0.10) / 2000$$

$$T = 0.003 \text{ seconds}$$

In other words, at 2000 ipm, 1 millisecond equates to 0.033 inches of tow displacement. This is a good illustration of just how hard the material is trying to pull on the blade. It also shows that the total accuracy and repeatability of the cutting system needs to be much better than a typical CNC scan rate (4 - 8 ms). Individual component repeatability (e.g. actuators, valves, etc.) must be in the sub-millisecond range or better. Further, the system for signaling a cut must have sub-millisecond resolution.

A fast moving blade enables flexibility and optimization of blade geometry. It also decreases the total cut cycle time (signal to end of cut), which decreases variability. To achieve this, Electroimpact developed a high speed cutting mechanism that allows cutting at high speeds with total cut times under 1 millisecond. This system also has very little variability, making tow placement accurate and repeatable even at very high laydown rates.

HIGH-SPEED FEEDING

Tows are cut at the end of a course. To start a new course, the tows must be fed back out to the nip point. As with cutting, there are numerous design options for feeding tow. Generally, there exists a motor, or motors, and rollers in conjunction with a system for slaving the tows to the rollers. Feed accuracy is equally critical in fiber placement as cut accuracy. And, as with cutting, there exist a number of challenges when on-the-fly rates are increased.

Feed Motor(s)

The feed motor (typically servo), or motors, are used to drive the tow from its cut position out to the nip point. The tow must arrive at the nip point traveling at the same rate as the machine, and also must arrive there at a precisely known time (position).

If a single motor and multiple actuators are used, or even if each tow has its own motor, the tow must be accelerated from rest to the laydown rate. Predictable acceleration of the tow is essential for feed accuracy. As the servo motor encounters a change in load there will be an increase in servo-delay (commanded velocity vs. actual velocity). Unless accounted for, tow placement accuracy can be adversely affected. Additionally, the final speed the tow reaches must match the laydown rate very closely. If fed slightly too fast, the tow will reach the nip point sooner than anticipated, and vice versa. As laydown rates increase, the inaccuracies due to motor control tend to also increase.

Given that the tow must be accelerated quickly and with high predictability, careful consideration of what is happening upstream of the feed system is required. Friction from dragging tows against guide chutes and losses from multiple redirect rollers can add to variability in feeding. Minimizing the number of redirects, simplifying tow paths and proper alignment of guidance systems becomes necessary for high-speed applications.

More considerably, the inertia of the raw material spool resists acceleration. Each cut and add operation requires stopping and starting the spool, so external means of controlling the dynamics of the spool are required. Active servo systems, though functional, tend to be highly complex both in controls and packaging. Each tow can require a plurality of sensitive sensors, motors, etc. With much simpler passive systems (spools allowed to freely rotate), the inertial hit of the spool can be reduced to a manageable level using a single "dancer" redirect roller and pneumatic disc brake. The dancer is allowed to move in the direction of tow with some resistive force. It is located adjacent to the spool and is the first roller the tow is led around. Tailoring the location, force, stroke and mass of the dancer roller can enable the passive system to be used for high on-the-fly starts and the disc brake enables the spool to be decelerated quickly for high speed cuts.

TIMING OF CUT AND ADD OPERATIONS

There are several factors that affect the timing of on-the-fly cutting and adding. These factors include program execution, output module reaction, solenoid valve actuation, airflow, inertial reactions of the actuating mechanisms, etc. Each of these factors provides a lag in the execution of a cut or add relative to the nominal signal. If the lag is predictable and repeatable, the cut timing can be compensated. These lags also need to be minimized where possible. From extensive development and testing at Electroimpact, the variability in lag for both feeding and cutting has been reduced below 1 millisecond, making end of cut or start of course placement very accurate at high speeds.

Controls

High-speed cutting and adding require extremely precise timing of the cut and add commands to their respective systems. Conventional controllers such as PLCs or CNCs generally operate on a "scan time", typically measured in milliseconds. Outputs are actuated once per scan, thereby limiting the timing resolution to the scan time. With a 1 millisecond delay resulting in a 0.033" end placement error at 2000"/minute, introducing a control error of even 1 millisecond would be unacceptable for high speed on-the-fly cuts or adds. Extremely tight integration of the CNC motion control and the timing of the cut and add commands is required to reduce the control timing delays to a minimum.

Electroimpact has chosen to utilize Fanuc's "Customer Board", a system that allows Electroimpact to interpolate the cutting and adding into the motion profile at the velocity command level of the CNC. This is the first implementation of the customer board outside Japan, and Electroimpact worked closely with Fanuc to implement features specifically for AFP applications. The control induced timing delays are in the range of microseconds, which effectively eliminates control timing delays as a source of error in cutting and adding.

Servo controls, including accuracy and following error

Servo lag, or following error, typically results in end placement deviations. Some systems compensate for anticipated following error in the programming system or early in the processing and attempt to adjust the commanded cut and add locations to minimize this affect. Generally these systems are successful at a limited range of speeds or require a fixed operating speed. True bi-directional operation may be impossible within the customer tolerances. Cutting and adding based on the actual machine position rather than the commanded machine position solves this problem. Cuts and adds are interpolated based on the true positions, effectively eliminating the servo delay as a source of cut and add errors regardless of cut and add speed, axis following error, or axis inertia.

This same technology allows operator override of the feedrate via a traditional 'feedrate override' with no effect on cut and add position. No "re-posting" or other programming change is required to change federates based on operating conditions or other events that may require a change in federate.

COMPACTION ROLLER AND CONFORMITY

Another obvious method for increasing the laydown rate is to increase the number of tows per machine – effectively widening the roller and course width. This would allow the machine to run at slower speeds, yet achieve similar throughput. However, this is not always plausible.

A compliant compaction roller is necessary to apply pressure to all tows laid on a part with complex contours. The shape and complexity of the contours on the part determine the amount of compliance necessary. The width of the roller should be matched to the shape and complexity of the part contours. Depending on roller design a wide roller on a part with high curvature may result in tows that are partially compacted or not compacted at all.

Compaction roller conformity can cause errors in the end placement of tows. As a simple example, a compaction roller on a curved section will deform as shown in Figure 3. Note that the non-uniform deformation of the compaction roller causes the length from the shear edge to the nip point on the part to vary from tow to tow. On a feed, the tows near the middle of the compaction roller

will reach the nip point sooner than the tows on the outer edges of the roller. On a cut, the middle tows will be cut shorter than the outer tows, even though the cutters are fired simultaneously. For a 12-inch wide roller operating on a 3-meter radius this length difference is 0.15 inches. And, for a 16-inch wide roller it is 0.27 inches. Both values are outside of typical customer end placement tolerances. Similar effects happen at any feature on the part requiring roller conformance, including ramps and pad-ups.

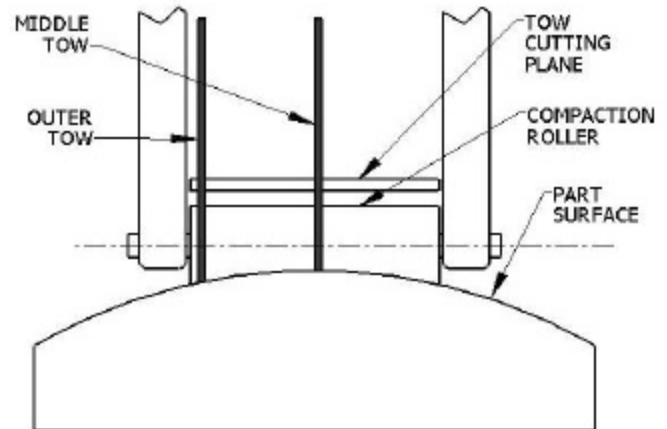

Figure 3 – Compaction Roller Conformity

End placement errors can also be caused when tows are not fully compacted during the feed. Any contour that causes non-uniform deformation of the compaction roller will affect tow end placement. The part programming system could potentially compensate for these effects. For the example given, the compensation would be fairly simple, however, accounting for all features would add substantial complexity in order to model both part geometry and specific roller conformity. A narrower roller in general reduces these errors, but requires the higher speeds achieved by Electroimpact to maintain high laydown rates.

PROGRAMMING SYSTEM

Programming of AFP machines is critical. Traditionally, the machine tool vendor has delivered AFP programming systems. However machine tool vendors do not generally excel at the type of programming required for an AFP programming system, or at providing updates for new operating systems, CAD software or computing hardware platforms.

Spirit AeroSystems has recognized the need for programming software to be provided by an industry recognized software provider as part of a standard suite of regularly updated and maintained software. The delivery of machines by competent machine tool vendors, with the delivery of programming systems by competent software vendors, mirrors practices in the mature metal removal industry. In that industry machine tool vendors by and large no longer attempt to compete

with far more competent programming companies like Mastercam, Gibbs and others.

Electroimpact recognized CGTech, with their Vericut Suite of software, as being very capable to provide machine independent AFP programming software. For over 2 years Electroimpact has been in a non-exclusive partnership with CGTech to developing AFP programming software called the "Vericut Composite Programming and Simulation Suite". Major aircraft manufacturers and their partners have tested this programming software over the last 2 years, and it will be used by Spirit Aerosystems to program these new AFP machines. The software will be updated and maintained by CGTech. For further information on the programming system contact CGTech.

The addition of a mathematically rigorous programming system has been demonstrated to eliminate end placement errors sometimes seen on machine tool manufacturer-developed programming systems. These programming system errors appear most frequently in tow convergence areas. They occur less frequently at ply boundaries.

CONCLUSION

Increasing part size, complexity, and high rate demand for composite lay-ups in the aerospace industry has created the need for machinery that can perform on-the-fly fiber placement at speeds of 2000 IPM. A complete reengineering of the cutting system and optimization of the feed system, tow path and creel system, and machine control system has yielded in-spec cutting and adding on-the-fly feeding at 2000 IPM and beyond. Additional refinement will certainly push speeds even higher. Many of the mentioned designs in this paper are patent pending.

REFERENCES

1. High Speed Tow Placement System for Complex Surfaces with Cut / Clamp / & Restart Capabilities at 85 m/min (3350 IPM). Luis Izco, Javier Isturiz and Manu Motilva, 2006 SAE International, Paper No. 2006-01-3138.

CONTACT

Russ DeVlieg, Mechanical Engineer, Electroimpact, Inc.
russsd@electroimpact.com

Kyle Jeffries, Mechanical Engineer, Electroimpact, Inc.
kylej@electroimpact.com

Peter Vogeli, Lead Engineer, Electroimpact, Inc.
peterv@electroimpact.com

CGTECH CONTACT INFORMATION:

For additional information on CGTech's "VERICUT Composite Programming and Simulation Suite contact CGTech's Bill Hasenjaeger - (949) 753-1050 x 270.
Bill.hasenjaeger@cgtech.com

DEFINITIONS, ACRONYMS, ABBREVIATIONS

AFP: Automated fiber placement

CFRP: Carbon fiber reinforced plastic

Cut Time: Time elapsed from the moment the edge of the blade enters the first fiber in a single tow until the last fiber in the tow is cut

IPM: Inches per minute

Laydown Rate: Amount of material applied to mold per unit time (typically pounds per hour).

Nip point: Tangent point between part and compaction roller

On-the-fly: Performing operations, such as cutting and adding of tow, in-motion.

Tow: Flat, thin bundle of carbon fibers and uncured resin. Commonly ~0.0075 inches thick and 1/8 inch wide. For widths greater than 1/8 inch, the manufacturing process changes and the material is referred to as "slit tape". For this paper, however, the term "tow" will envelope a multitude of sizes.